



# Windmill Primary

## NEWSLETTER

Term 4 – 18<sup>th</sup> March 2024

### Principal's message

At the penultimate week of term, the learning has not slowed down at all. Year 1 have been busy with their hot write, while Year 2 were busy learning about the Torah. Year 3 have been busy writing sentences with adverbs and other features to improve their writing. Year 4, had an amazing time looking at circuits and Year 5 were writing about mythical creatures. Year 6 were busy with decimals and fractions. I am certainly looking forward to seeing this hard work continue next week. I hope you all enjoy the sunshine this weekend and see you next week for the last 4 days of the term.



### Upcoming Dates

27th March	Lunch bookings close for first week back at 10pm
28th March	Easter Bonnet Day
28th March	Chocolate Tombola – 3.30pm - Main Hall
28th March	End of School Term 4
15th Apr	Start of Term 5
2 <sup>nd</sup> May	School Closed for Polling Station
16th May	Italian Theme Lunch Day – book on WisePay by 10pm on Thursday 9th May
24th May	End of Term 5
3 <sup>rd</sup> June	Start of Term 6
18th June	Sports Day Reception, Y1 & Y2 9:15-10:30 am and Years 3, 4, 5 & 6 1:15-2:30pm (weather dependent)
19th July	End of Term 6

Respect Courage Compassion Honesty Ambition Resilience Responsibility Unity

## Windmill's Wonderful Work

Reception enjoyed a visit to the church this week. We have learning about celebrations including celebrating a new baby. We took part in a baptism and took dolls to baptize. We then explored the church and thoroughly enjoyed our visit.



Please check tapestry for more photos of our visit. Thank you once again to all the adults who came to support our visit.

In Art, the children have begun to create their textile self-portraits. Today, we drew/painted ourselves, ready for next week - where we will be adding different materials.



# Windmill's Wonderful Work

In Art we have been exploring collaging. We have used a variety of materials to create abstract collages. We have been inspired by the artist Katie Vernon who uses her knowledge of being a florist to help her create collages using flowers.



Year 3 had an awesome time this week setting up an experiment to show how water is transported through flowers.



## Windmill's Wonderful Work

In Science this week, Year 4 have been exploring which materials are conductors of electricity and which are insulators of electricity. We found out that stainless steel and foil conduct electricity and make our simple series circuits complete by the light bulb illuminating. We also found out that paper, foam and wood do not allow the electricity to flow through, therefore they are insulators.

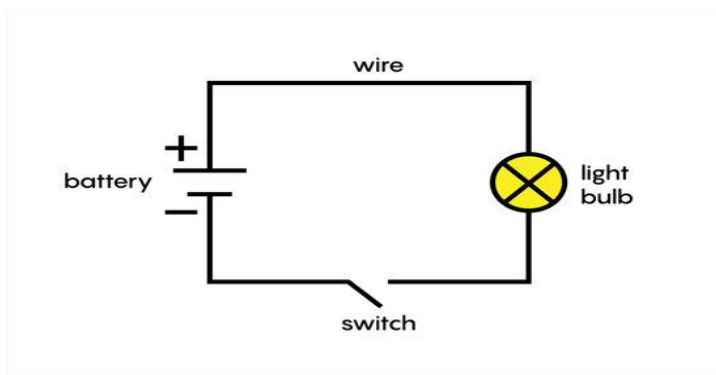

Year 5 have been very busy this week! We have been innovating our own report about Mountain Giants, we will be creating our own report on mythical creatures next week and we can't wait to see the children's ideas!

We have also been honing our mathematical skills with fractions. It has been tricky at times but the children have shown great resilience and perseverance to understand the concepts.

We have our last swimming session next week (Thursday 28th) so please make sure your child has their swimming kit with them for the all important assessment week!



## Windmill's Wonderful Work

Year 6 have been creatively crafting three dimensional art work this week as we were inspired by the work of Dale Chihuly. We had lots of smiling faces as we shared feedback of their mock SAT experience. Please look out for the information letter your child brought home this week with more information about the SATs as well as their invitation to the Easter Booster sessions.



### *NHS School Nurse*

*Did you know that every school has a named NHS school nurse? We are a team of Qualified School Nurses, Community Staff Nurses, Healthy Child Practitioners and School Nurse Assistants. We work all year-round Monday to Friday (excluding Bank Holidays). We are happy to provide information, advice and guidance on a range of health needs from reception to Year 13.*

*We can be contacted:*

- *By phone 0800 170 7055 option 4*
  - *Live Chat: <https://www.nhft.nhs.uk/0-19>*
  - *[www.nhft.nhs.uk/childrenshub](http://www.nhft.nhs.uk/childrenshub)*
  - *Chat Health (our text-based School Nurse messaging service) for parents and young people aged 11 and over. Monday to Friday 8.30-4.30 pm - 07507 329600*
  - *On "X" (was Twitter) SchoolNursesNHFT*
- You can also contact us for any school aged immunisation queries.*
- *By phone: 0800 170 7055 option 5*
  - *Website: [Children's resources, tips and advice hub | NHFT](#)*

# Windmill Updates

## Pupil Premium

Is your child eligible for free school meals?

If you can answer yes to any of these questions below then you can get your child registered for free school meals with the bonus of Windmill getting extra funding to support your child's learning in school.

- Are you on income support?
- Do you claim Job Seeker's Allowance?
- Do you claim Child Tax Credit?
- Do you claim Working Tax credit run on?
- Do you get Universal credit?

## Your child doesn't need to have the meals.

The Pupil Premium funding allows us to provide a range of interventions and resources, tailored specifically to meet the individual needs of your child. This may include extra teaching support, one-to-one tuition, mentoring programs, or additional learning resources. By utilising the Pupil Premium funding effectively, we can help your child make excellent progress and achieve their full academic potential.

## Lunches – Summer Term 1

Lunch bookings for next term are now live. Lunches for the first week back after Easter must be booked by 10pm on Wednesday 27th March to allow numbers to be submitted before the office closes for Easter. Any problems, please email [adoe@windmillprimary.net](mailto:adoe@windmillprimary.net) as soon as possible.

We also have a special Italian theme day on Thursday 16th May where lunchtime will be all things Italian.



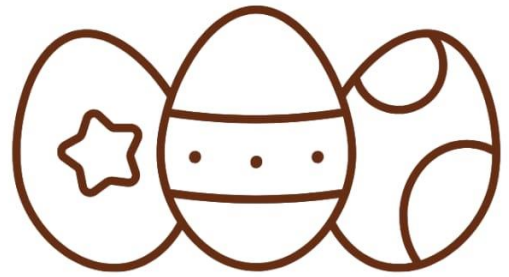
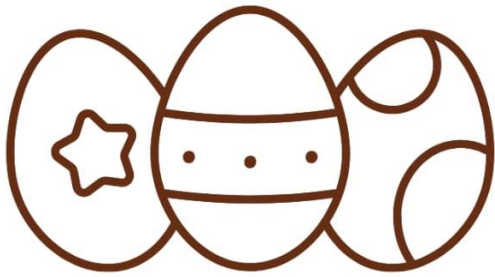

## RWSA

# Chocolate Tombola

Please join us in the school main hall on  
Thursday 28th March from 3:30pm  
for the RWSA's annual chocolate tombola.



**Tickets are 50p each or 3 for £1**



Students in afterschool club will be able  
to attend if provided with money for  
raffle tickets.



